



JOINT INSTITUTE FOR NUCLEAR RESEARCH

Veksler and Baldin laboratory of High Energy Physics

# **FINAL REPORT ON THE SUMMER STUDENT PROGRAM**

*Superconducting Magnets for NICA Collider*

**Supervisor:**

Dr. Sergey Alexandrovich Kostromin

**Students:**

Alexey Bulygin

Valerya Mekhanikova

Maksim Trushin  
NRNU MEPHI

**Participation period:**

July 01 – July 31

Dubna, 2016

# CONTENTS

INTRODUCTION .....	1
MEASUREMENT METHOD.....	4
The fluxmeter method .....	4
Induction coils .....	4
The flux measurement.....	4
Hall probe measurements .....	5
Magnetic resonance techniques .....	5
Fluxgate magnetometer .....	6
Visual field mapping .....	7
THE HARMONIC-COIL METHOD. ....	7
VFC integrator and angular encoder .....	7
Servo Motor.....	8
Description of the harmonic method. ....	9
Fourier analysis.....	9
Math model .....	10
PRODUCTION OF MAGNETS .....	13
MULTIMETER .....	22

## INTRODUCTION

At nuclear center in Dubna the construction of a collider of protons and heavy particles of NICA is carried. By means of it scientists will study a special status of matter in which our Universe soon after the Big Bang — a quark–gluon plasma stayed.

NICA includes two preliminary accelerators (Fig. 1). As the main dispersing accelerator Nuclotron use already constructed in 1992. The second accelerator is the booster synchrotron which will be constructed in the ring which remained from a Synchrophasotron.

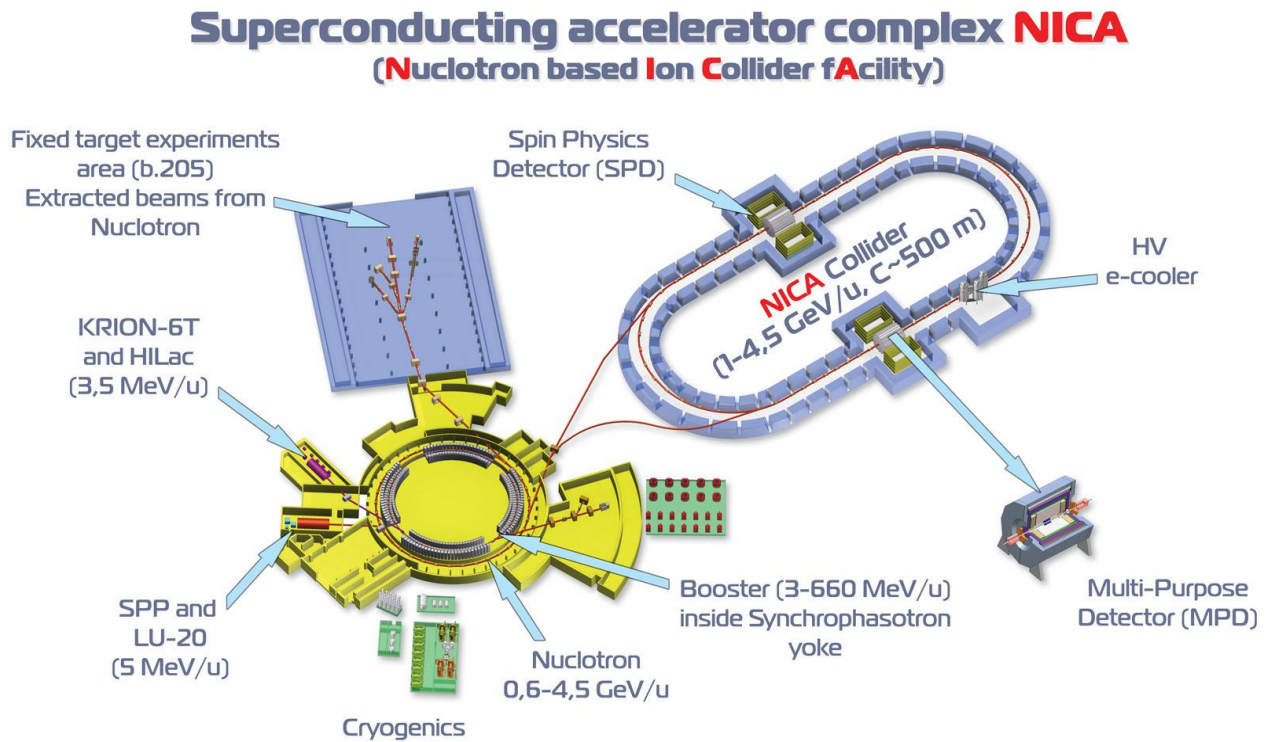

Fig. 1

In our scientific-experimental division of superconducting magnets and technology plans to collect 40 dipole magnets of the Booster of the NICA (Fig.2 (c)), 48 quadrupole magnets with multipole correctors Booster NICA (Fig.2 (b)), 80 dipole magnets for the NICA Collider (Fig.2 (a)), 86 quadrupole magnets with multipole correctors Collider NICA, as well as for the synchrotron SIS100 (FAIR project international, adopted at the GSI, Darmstadt) 175 quadrupole magnets with multipole correctors.



(a)

(b)

(c)

Fig.2 Types of magnets. (a) the dipole magnet of the collider; (b)the quadrupole magnet; (c) the dipole magnet of the Booster

Magnets for the NICA booster is curved (Fig. 3), with small enough radius of curvature is 14 meters. From the dipole magnet for SIS100 curvature radius of 52 meters. Collect and test such curved magnets are much more complicated than straight. To resolve this problem, it were made five frameworks, presenting a single curved magnet five short (Fig. 4). Then, summing all five magnets got his measure. If I went on an alternative path, for example, would make the curves of the frame or moved them horizontally, then the measurement system were dramatically more expensive, and also would have lost on time.



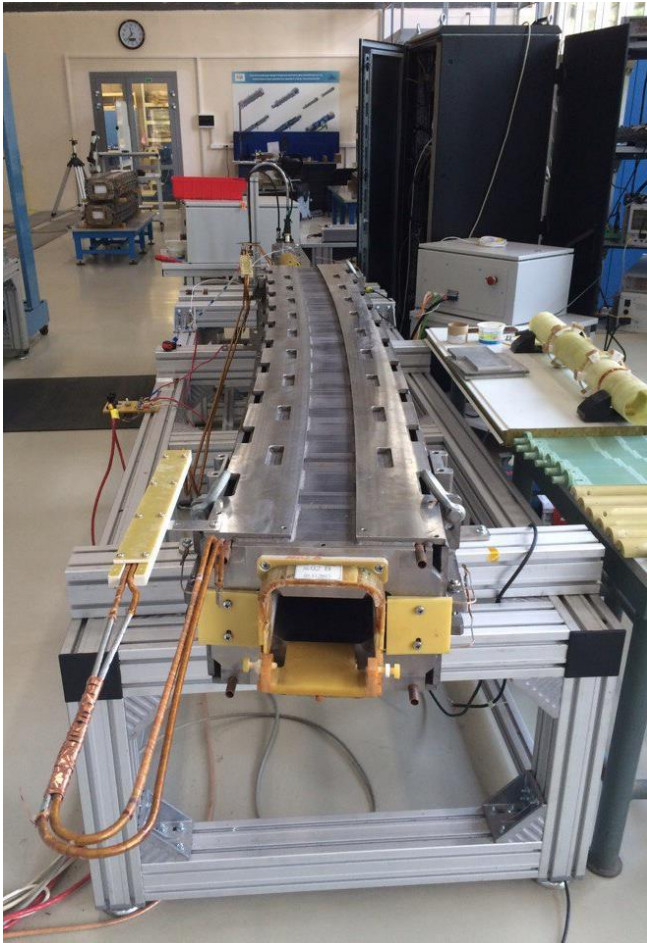

Fig. 3



Fig. 4

## MEASUREMENT METHOD.

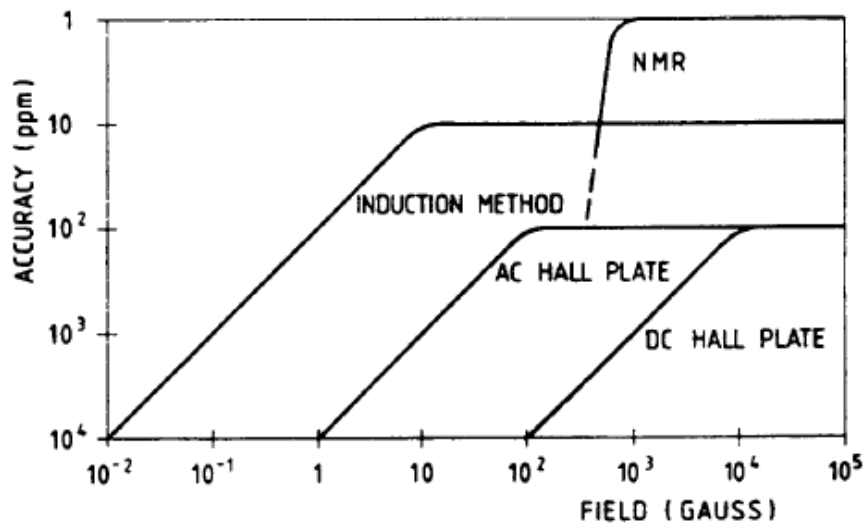

Fig.5 Measurement methods: accuracies and ranges

### The fluxmeter method

This method is based on the induction law. It is the most important method for particle accelerator magnets and also the most precise method for measuring the direction of the magnetic flux lines. Measurements are performed either by using fixed coils in a dynamic magnetic field, or by moving the coils in a static field.

### Induction coils

The coil method is particularly suited for measurements with long coils in beam-guidance magnets, where the precise measurement of the field integral along the particle trajectory is the main concern. The search coil is usually wound on a core made from a mechanically stable material, in order to ensure a constant coil area, and the wire is carefully glued to the core.

This method is very popular for use in magnets with circular cylindrical geometry. Harmonic coil measurements are the best choice for most types of accelerator magnets.

Advantages of search coil techniques are the possibility of a very flexible design of coil and high stability of the effective coil surface. Disadvantages are large induction coils and relatively slow measurements in static fields.

### The flux measurement

The coil method was improved with the development of digital voltmeter and Miller integrator. Later in Cern was created new type of digital integrator, which is based on a high quality dc amplifier connected to a voltage-to-frequency converter (VFC) and a counter. Figure 6 shows an example of such an integrator.

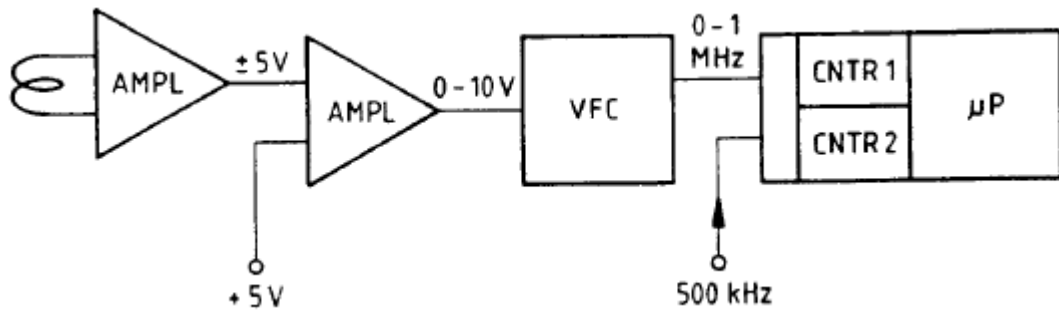

Fig.6 Digital integrator (Cern)

This system is well adapted to digital control but imposes limits on the rate of change of the flux since the input signal must never exceed the voltage level of the VFC.

### Hall probe measurements

The Hall-generator provides an instant measurement, offers a compact probe, suitable for point measurements. The probes can be mounted on relatively light positioning gear. The wide dynamic range and the possibility of static operation are attractive features.

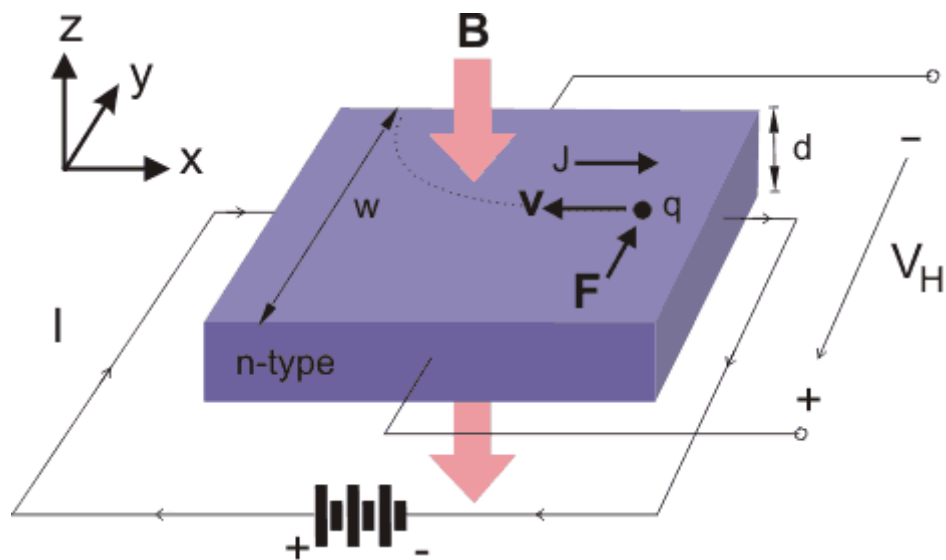

Fig. 7 Schematic diagram of the Hall effect.

The Hall generator of the cruciform type shows a better linearity and has a smaller active surface than the usual rectangular generator. The measurement of the Hall voltage sets a limit of about 20  $\mu\text{T}$  on the sensitivity and resolution of the measurement, if conventional direct current excitation is applied to the probe. This is mainly caused by thermally induced voltages in cables and connectors.

### Magnetic resonance techniques

The method has become the most important way of measuring magnetic fields with high precision. It is considered as a primary standard for calibration. Based on easy and precise frequency measurement it is independent of temperature variations.



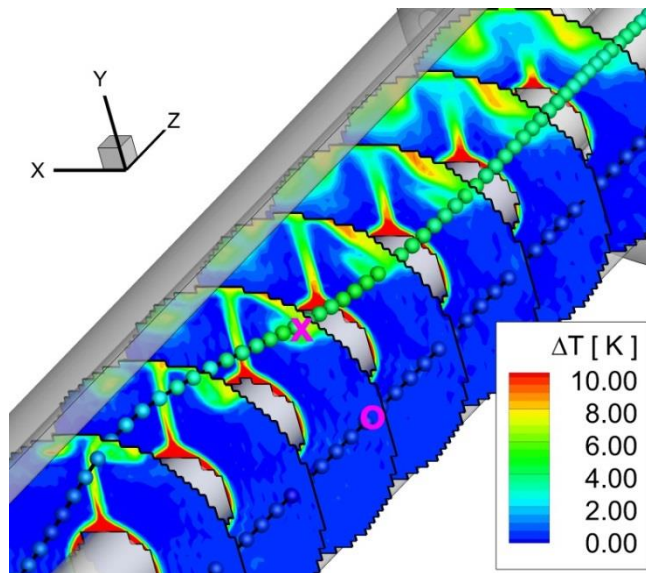

Fig. 8 Temperature difference field measured using the MRT technique.

The advantages of the method are its very high accuracy, its linearity and the static operation of the system. The most important disadvantage is the need for a rather homogeneous field in order to obtain a sufficiently coherent signal.

Magnetic resonance imaging (MRI) has been proposed for accelerator magnet measurements.

### Fluxgate magnetometer

The fluxgate magnetometer is based on a ferromagnetic core on which detection and excitation coils are wound. The core is made up from a fine wire of Mumetal or a similar material than has an almost rectangular hysteresis curve. The method is restricted to use with low fields, but has the advantage of offering a linear measurement and is well suited for static operation. Also it is suitable for studies of weak stray fields around accelerator or detector magnets.

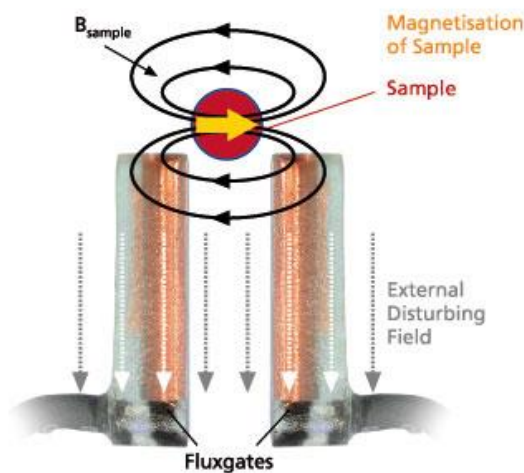

Fig. 9 Fluxgate-Magnetometer

## Visual field mapping

Visual field mapper is made by spreading iron powder on a horizontal surface placed near a magnetic source, thus providing a simple picture of the distribution of flux lines.

## **THE HARMONIC-COIL METHOD.**

This method requires careful and extensive design and fabrication. The harmonic coil method is simply a generalization of the above development to measure the phase and amplitude of any harmonic component of the field. The resulting accuracy is estimated for different designs commonly in use in devices based on the harmonic-coil method.

The main problem is achievement a full two-dimensional measurement of the field in a cylindrical aperture.

## VFC integrator and angular encoder

Let's talk about integrator and schematic diagram of a harmonic coil system. Figure 10 shows design using a multitrack absolute encoder.

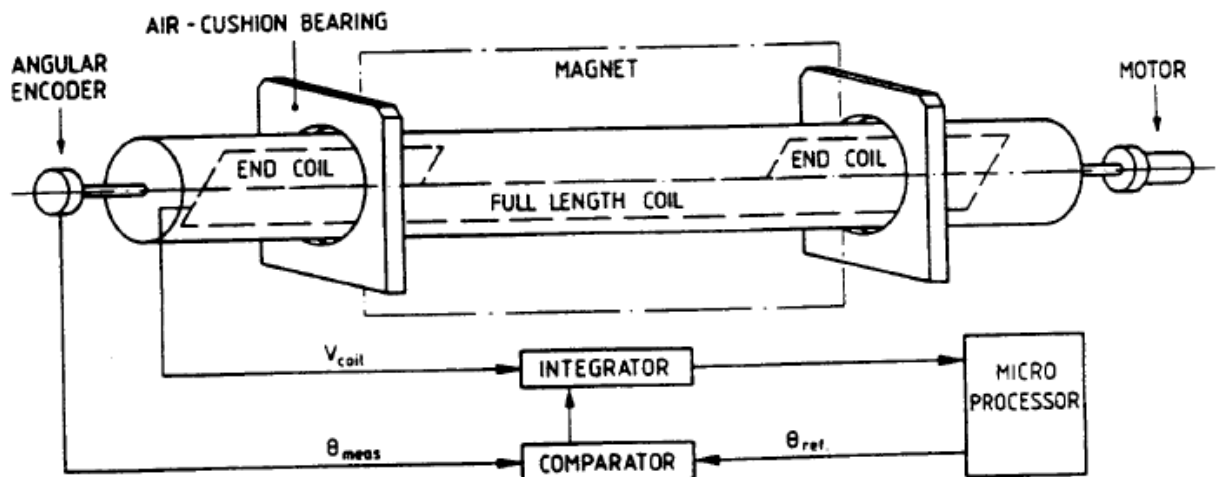

Fig. 10 Schematic diagram of a harmonic coil system.

The set of coils is mounted on a cylindrical frame which is longer than the magnet to be measured. The comparator triggers the integrator at angular positions measured by a multitrack absolute encoder.

### **Description:**

1. The processor controlling the measurement feeds the comparator with the next angle of the measurement.
2. Once the encoder reaches that position, the integrator receives a trigger than latches the content of the counters for reading and resets them zero.
3. A pair of counters is used on integrators so that one is counting whilst the order is read by the processor then reset to zero.

4. The trigger from the encoder has just to change the direction of the output of the VFC from one counter to the other.

5. One full turn of the measuring coil takes typically from 1 to 60 seconds.

### **Servo Motor**



Fig. 11 Kollmorgen [AKM Series Servo Motor](#)

The angle positions were given by stepping motors (Fig. 11) or by mechanical wheels with teeth to attain high precision, while early harmonic coil systems had to rotate stepwise between consecutive angular positions to allow the reading and reset of the integrator on each angular position.

Following the data acquisition, a computer sums up the contributions of the incremental integrated voltages, performs the Fourier analysis, and then divides each term obtained by the corresponding geometrical sensitivity of the coil.

The current supply of the magnet must be extremely reproducible to obtain a reasonable precision.

The measuring sequences become:

1. Reset the integrator with no current in the magnet
2. Go to specified current and read the integrator
3. Reset the integrator and integrate when the current goes back to zero to allow drift cancellation by averaging with the previous measurement

4. Go to the next angular position

#### **Description of the harmonic method.**

The use of a voltage integrator connected to the measuring coil makes it possible to eliminate the time coordinate in the induction law of Faraday. The voltage integrator read as a function of the angle gives directly the flux from the zero angle where it is reset.

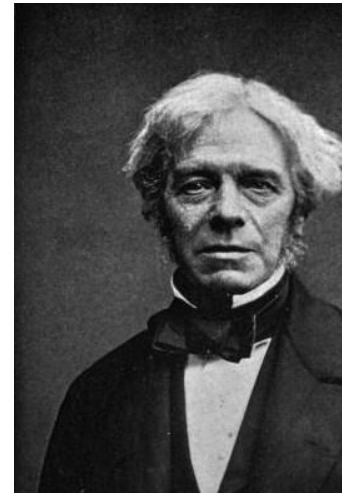
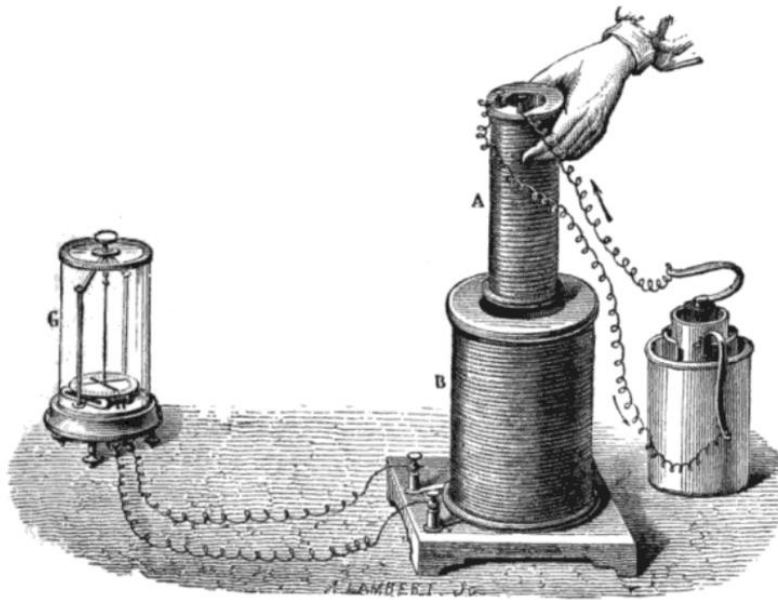

Fig. 12 Faraday and his induction experiment.

The length of the measuring coil follows a compromise between, on the other hand, the mechanical stability of the frame holding the coils and the ease of winding these, and of the other hand a too large number of longitudinal positions needed to measure the whole magnet.

The definition of the harmonic number used in this report,  $n = 1$  for the dipole,  $n = 2$  for quadrupole, etc., implies that the sensitivity is proportional to the rotation radii to the power of the harmonic order considered, and that the angular dependence of the flux is proportional to the order.

The harmonic coil method is most suitable for small and cylindrical apertures.

#### **Fourier analysis.**

The system has to make a Fourier analysis of the flux curve, after some treatment of the raw data collected. For this purpose a Fast Fourier Transform (FFT) algorithm is used. Since the function is periodic and the result is a Fourier series it is simpler to choose an encoder having  $2^N$  points per turn.

A full three-dimensional analysis shows that a flux integrated over the length of the rotating coil represents the integrated field or harmonic if the axial component of the field is zero over the two end faces of the coil. The ends are measured separately from the integral of the field over the full magnet.

A Fourier analysis of the measured curve thus gives a description of the parameters of the field: amplitudes of harmonics of the field, coordinates of the displacement or resulting dipole component.

The main contribution to sum of the incremental integrated voltages is equal to the drift of the integrator over the time needed for full turn.

**Math model**

Magnetic field has cylindrical symmetry with respect to the axis OZ. In this case components of magnetic induction have a look:

$$B_r(\theta) = \sum_{n=1}^{\infty} \left[ \left( \frac{r}{R_{ref}} \right)^{n-1} (a_n \cos n\theta + b_n \sin n\theta) \right] \tag{1}$$

$$B_{\theta}(\theta) = \sum_{n=1}^{\infty} \left[ \left( \frac{r}{R_{ref}} \right)^{n-1} (-a_n \sin n\theta + b_n \cos n\theta) \right] \tag{2}$$

Frame rotates along an axis OZ on radius R<sub>1</sub> and R<sub>2</sub>. It has length L<sub>coil</sub> and numbers of coils w. It's needed to find coefficients a<sub>n</sub> and b<sub>n</sub>.

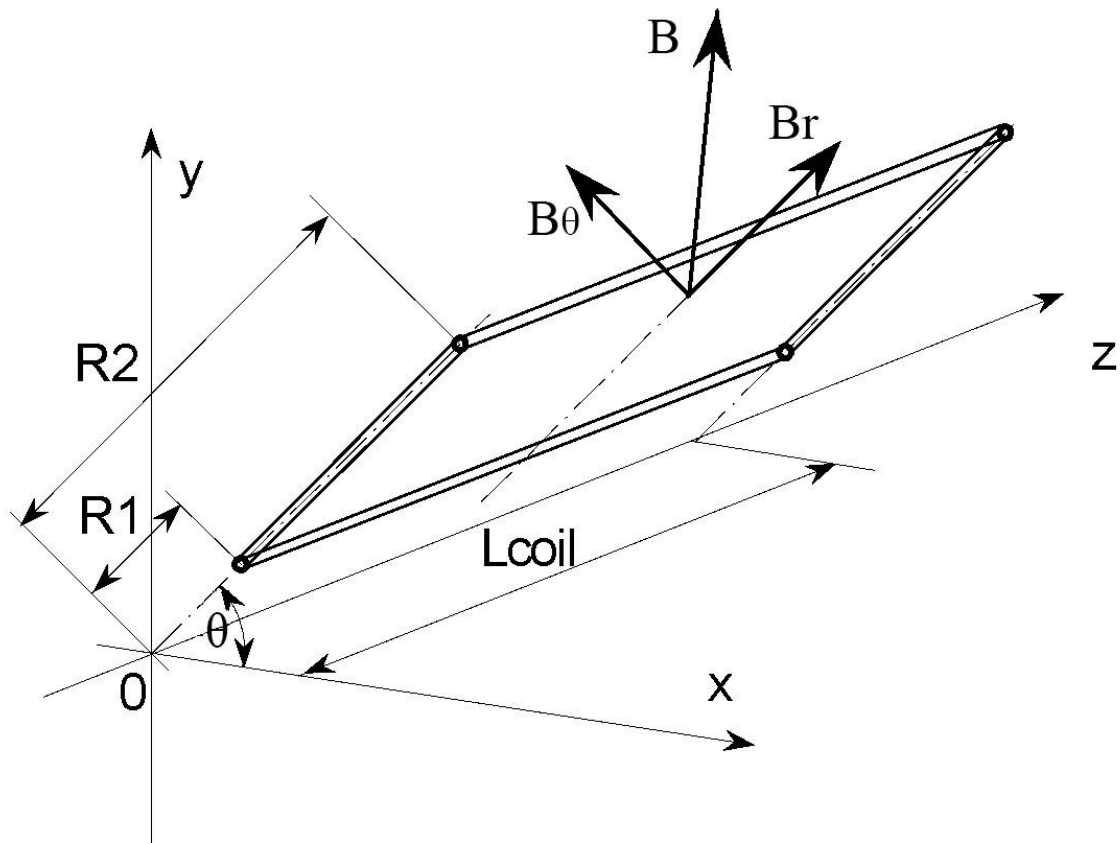

Fig. 13 A coil for measurements of magnetic field

The magnetic flux associated with the coil:

$$\Phi(\theta) = L_{coil}W \int_{R_1}^{R_2} \left[ \sum_{n=1}^{\infty} \left( \frac{r}{R_{ref}} \right)^{n-1} (-a_n \cos n\theta + b_n \sin n\theta) \right] dr \quad (3)$$

The *integral* of a function  $\Phi(\theta)$  over the *interval*  $[R_1, R_2]$  is equal:

$$\Phi(\theta) = L_{coil}W \sum_{n=1}^{\infty} \left[ \frac{R_{ref}}{n} \left\{ \left( \frac{R_2}{R_{ref}} \right)^n - \left( \frac{R_1}{R_{ref}} \right)^n \right\} (-a_n \cos n\theta + b_n \sin n\theta) \right] \quad (4)$$

The relationship between integrated voltage for different angles  $\theta$  and magnetic flux is:

$$\Phi(\theta) = \int U(t) dt \quad (5)$$

Fourier series representation of a function  $\Phi(\theta)$ :

$$\Phi(\theta) = \int U(t) dt = \sum_{n=1}^{\infty} (A_n \cos n\theta + B_n \sin n\theta) \quad (6)$$

Since from (4) and (6):

$$a_n = -A_n \frac{n}{L_{coil}W R_{ref} \left( \left( \frac{R_2}{R_{ref}} \right)^n - \left( \frac{R_1}{R_{ref}} \right)^n \right)} = -A_n \frac{1}{S_n} \quad (7)$$

$$b_n = B_n \frac{n}{L_{coil}W R_{ref} \left( \left( \frac{R_2}{R_{ref}} \right)^n - \left( \frac{R_1}{R_{ref}} \right)^n \right)} = B_n \frac{1}{S_n} \quad (8)$$

$S_n$  – “area” of coil for harmonic number  $n$ .

Real coils consist of windings which are distributed in space. In this case it's needed to calculate other integral of magnetic flux.



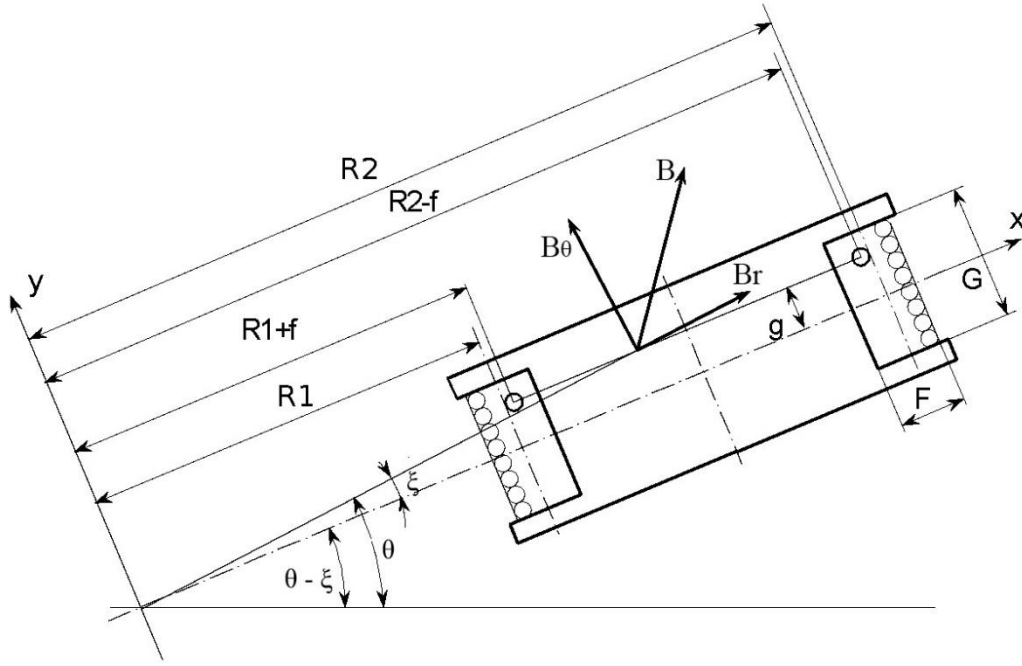

Fig. 14 A coil consist of windings which are distributed in space

Projection of a vector B onto an axis y:

$$B_y = B_r \sin \xi + B_\theta \cos \xi \quad (9)$$

Fourier series representation of a function  $B_r$  and  $B_\theta$ , and equation (9) gives:

$$B_y = \sum_{n=1}^{\infty} \left[ \left( \frac{r}{R_{ref}} \right)^{n-1} (\cos n\theta \{b_n \sin(n-1)\xi - a_n \cos(n-1)\xi\} + \sin n\theta \{a_n \sin(n-1)\xi + b_n \cos(n-1)\xi\}) \right] \quad (10)$$

The magnetic flux is:

$$\Phi = \frac{W}{FG} L_{coil} \int_{-\frac{F}{2}}^{\frac{F}{2}} \int_{-\frac{G}{2}}^{\frac{G}{2}} \int_{R_1+f}^{R_2-f} B_y df dg dx \quad (11)$$

From figure 14:

$$r = \sqrt{x^2 + g^2} \quad (12)$$

$$\xi = \tan^{-1} \left( \frac{g}{x} \right) \quad (13)$$

The result can be generalized:

$$\Phi = \frac{W}{FG} L_{coil} \sum_{n=1}^{\infty} (-a_n \cos n\theta + b_n \sin n\theta) \times$$

$$\times \int_{-\frac{F}{2}}^{\frac{F}{2}} \int_{-\frac{G}{2}}^{\frac{G}{2}} \int_{R_1+f}^{R_2-f} \left( \frac{\sqrt{x^2 + g^2}}{R_{ref}} \right)^{n-1} \cos \left( (n-1) \tan^{-1} \left( \frac{g}{x} \right) \right) df dg dx$$
(14)

A similar relationship ((6) and (7)) holds for frame:

$$S_n = \frac{W}{FG} L_{coil} \int_{-\frac{F}{2}}^{\frac{F}{2}} \int_{-\frac{G}{2}}^{\frac{G}{2}} \int_{R_1+f}^{R_2-f} \left( \frac{\sqrt{x^2 + g^2}}{R_{ref}} \right)^{n-1} \cos \left( (n-1) \tan^{-1} \left( \frac{g}{x} \right) \right) df dg dx$$
(15)

## PRODUCTION OF MAGNETS

As any difficult process, assembly of magnets consists of several stages.

The initial stage. The Savelovsky machine-building factory is initially manufactures the metal part of the magnet according to the requirement of drawing.

Theorists of the accelerator Department set parameters for the magnet and the designers on them begin to engage in the content, General design, and many others, i.e. solve design problems.

Then it is consistent with the technologists. Together they appreciate the ability to build one type of magnet. When the magnet after fabrication enters the Department, they check that all the dimensions were accurate, and all meet the drawing requirements.

It does in parallel with superconducting windings. It consists of several stages. At first there is a winding of a superconductor on a tube.

The superconductor may be wound outside the magnet, and therefore, is cooled from the outside. Superconductor under our technology is wound on the tube and be cooled centrifugal liquid helium. And on top of the superconductor is applied to the insulating sheath. In a further superconductor betray the form and make the coil or under

lick quadrupole or dipole. This is because under the quadrupole lens is necessary to create the four poles, under dipole or two. After the manufacture of the winding check on its geometry, internal resistance, inductance. Its characteristics must conform to technical specification.



After all the thorough checks of the yoke of the magnet, the windings collect the magnet and make the kind of measure to identify manufacturing defects associated with materials or assembly. It checks on two different stands, because for each type of magnet has its own system of installing and fixing. One stand is for a dipole magnet, and the other is for the quadrupole magnet (Fig. 15).



Fig. 15. Stand for quadrupole magnets

To check magnet use one of the types of electric motors, it is the stepper(Fig.6).Its important function is the ability to turn at a certain angle. The engine via a clutch rotates the spool and sets the required angle. One step corresponds to  $1/64$  of a turn. The engine itself is a launching. But also it needs the servo system with feedback. Sensor, a





so-called encoder, shows how actually turned the coil. Using this system it is possible to calculate the mechanical errors in bearings, couplings, as well as fix the exact angle and accurately analyze the ability of

the engine to do a full rotation.



Fig. 16. Stepper motor and “slipping rings”

The next stage is preparing the magnet for the cold measurements, i.e., a supply of helium in the winding. In order to accomplish this, the designers cryogenic Department develop special connections. It is needed in order to avoid malfunctions when you check the magnet. For example, the radius of the tube must be of a certain size, so that it was easy to mount the right parts.

First connect system, which fed helium to cool the magnet, then the magnet is mounted in a special cryostat (Fig. 17). It includes nitrogen shield which is needed to avoid too much temperature difference. The layout issues are resolved to the constructor, i.e. the creation of conditions in order to make it convenient to get hold of a tube of liquid helium and dock with each other modules.

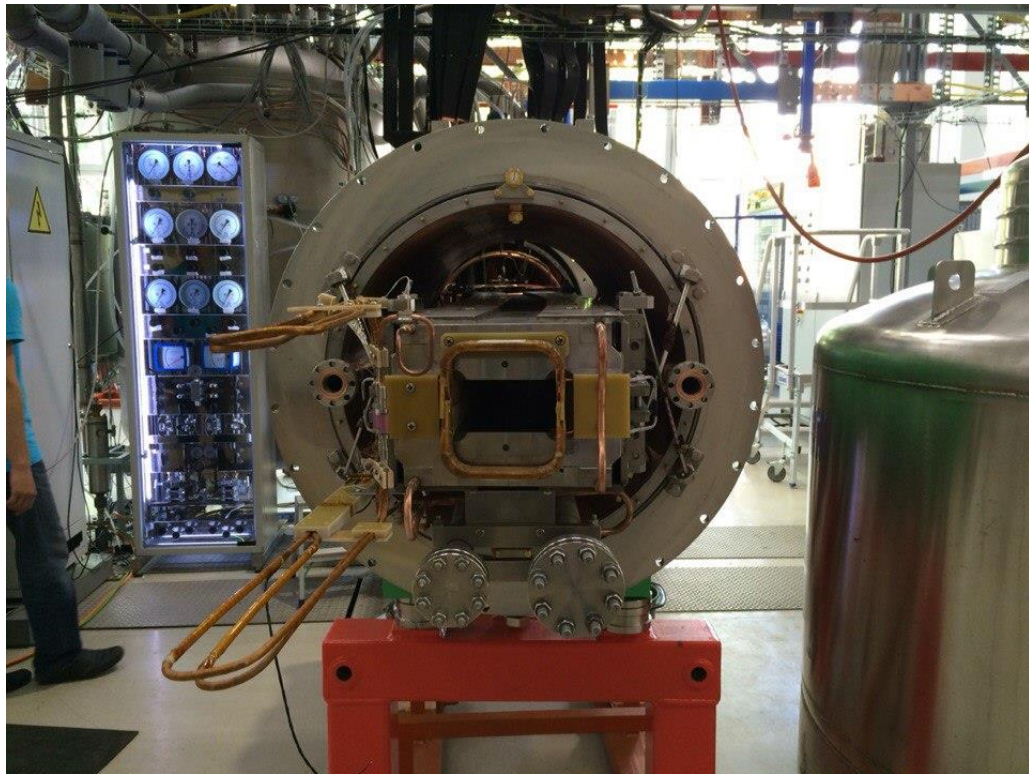

Fig. 17. The cryostat for the cold test of the magnets

Then the magnet is directly transmitted to the installation tests. On it is supplied current through current leads cryostat (Fig. 18), to be able to connect all the cooling system. Current leads cryostat is universal. You can connect as a quadrupole magnet and a dipole.



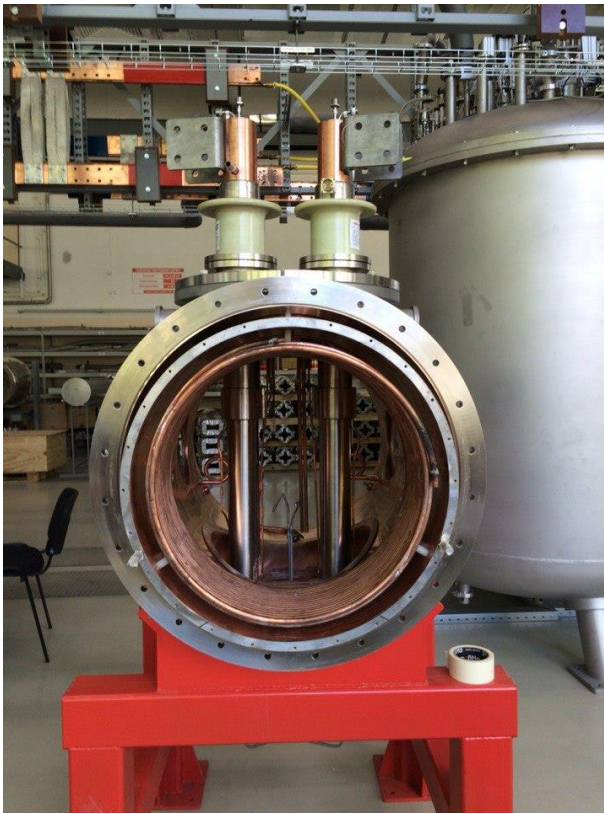

Fig. 18. Current leads cryostat



Fig.19. current leads the cryostat from the inside



Fig. 20. Extracted from the cryostat current leads





When the whole system will begin to cool, its inevitable deformation. Therefore, in the present compensating devices.

Cooling is gradual, dropping the temperature to the moment when you get to operating temperature ( $t_{He}^{\circ} = 4,2K$ ). After the magnet is cooled, its impossible to dismantle. Because the magnet is precipitated moisture due to the fact that there was a vacuum. And launching the moist air, there is a sharp drop in temperature, as a consequence, a snow "fur coat".

When checking a cooling with liquid helium, in the cryostat the vacuum has to be supported. For this purpose in system

diffusive pumps are used.

Cold measurements are conditions which completely repeat working conditions in the accelerator. If the magnet works well, i.e. shows all the parameters, there are no failures, then it is dismantled from there and put the following magnet in line.

Since the moment as the magnet was connected to the cooled system until when it is dismantled, there pass about one and a half weeks.





Fig. 21. Current source

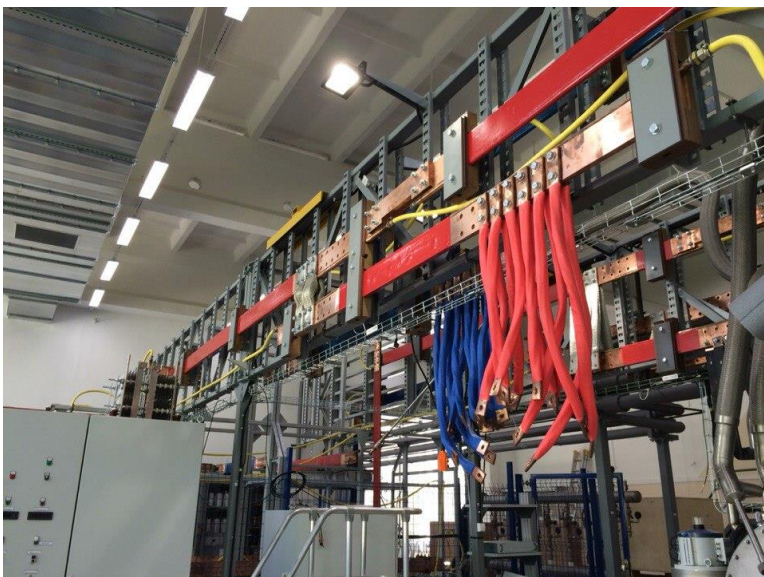
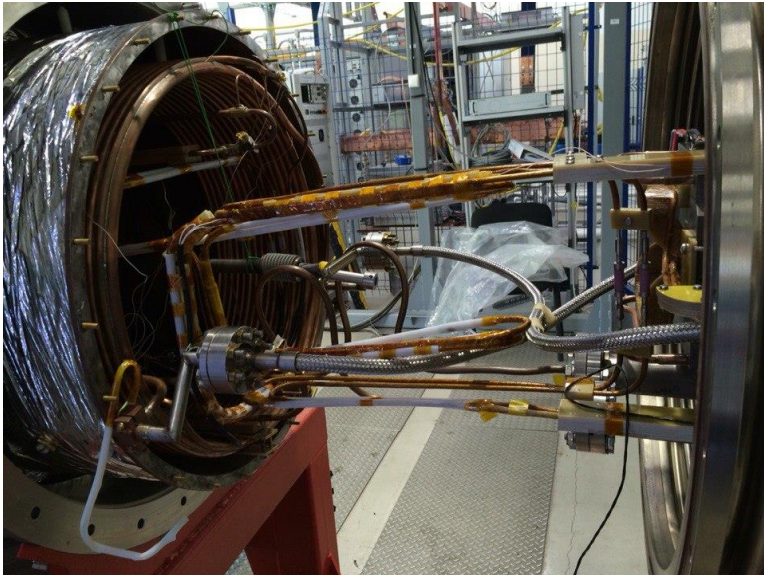

## MULTIMETER

In our laboratory, engineers using only precision and quality modern equipment. One of these precision instruments was studied in detail. Digital is a high-performance 6½ digit multimeter Keysight 34465A. It provides high resolution, accuracy and measurement speed.



Engineers using this multimeter have the ability to visualize the measurement results in various ways, also it helps you to get the information you need and simplifies the documentation of results. Enhanced graphics capabilities of a digital multimeter Keysight 34465A such as trend graphs and histograms help engineers deeper and faster to understand what was going on.

This device has a huge memory – 2 000 000 measurements. New readings are stored instead of the oldest stored measurements; the new dimensions are always maintained. In addition, it can measure very small currents (1  $\mu$ A range with picosecond resolution) that allow getting measurements of over low-power devices.



With it you can measure DC voltage, AC voltage, AC and DC currents, temperature, capacitance, continuity, frequency and period and to test the diode.

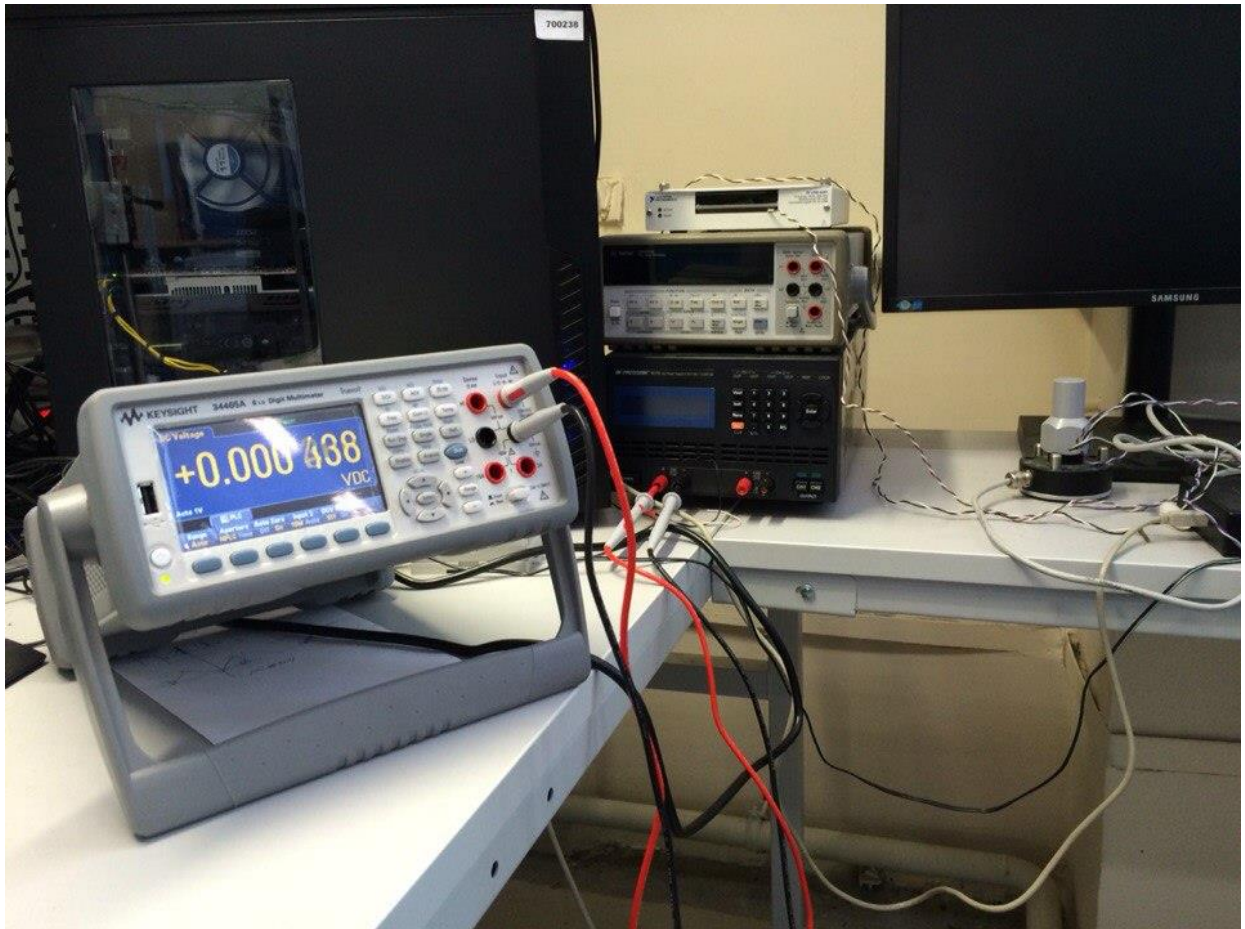

Multimeter Keysight 34465A supports file access, which provides standard digital multimeter connected to computers via USB port. In addition, it provides a function of dragging data with mouse, allows you to configure the device parameters and can transfer screen shots in computer applications without additional software.

BenchVue software allows you to control digital multimeters Keysight simultaneously with other Keysight benchtop instruments without additional programming. With one click, the engineer can transfer the data to PC through USB, LAN or GPIB for additional viewing and analysis.

Real signals are never clean and quiet. They often contain a variable component, induced from the power supply or other noise, for example caused by electromagnetic interference. The ability of the DMM to cope with such external shocks and to eliminate their influence on the measurement results has a positive effect on the achievable accuracy. Using patented technology analog-digital conversion, digital multimeters

Keysight Truevolt series take into account errors created by these common sources of interference, so engineers can be confident in their measurements.



## REFERENCES

- [1] S.Turner, Magnetic measurement and alignment, Geneva, 1992.
- [2] S.Turner, Measurement and alignment of accelerator and detector magnets, Geneva, 1998.
- [3] <http://madx.web.cern.ch/madx/>

## List of electronics.

Applied devices are in laboratory.

- 1) Digital Multimeter Agilent 3458A
- 2) Digital Multimeter Agilent 34401A
- 3) Programmable DC Power Supplies BK precision 9151
- 4) Dual Range DC Power Supplies BK precision 9173
- 5) Power Supplies GW instek GPS-72303 and GPR-76060d
- 6) Power supply Danfysik System 8500
- 7) Direct Drive Rotary Motors Kollmorgen Housed DDR dh061m-22-1310
- 8) Nanovoltmeter Keithley 2182a
- 9) Waveform generator Keysight 33600A
- 10) Digital Multimeter Keysight 34465A
- 11) Universal Frequency Counter Timer Keysight 53230A 350 MHz
- 12) [DC Current Source](#) Keithley 6221
  
- 13) Direct Drive Rotary Motors Kollmorgen akm53g
  
  
- 14) Motor Mitsubishi hf-sp1024B
  
  
- 15) Gaussmeter Lake Shore Model 475
- 16) Power supply PS 260
- 17) LCR Bridge/Meter Rohde & Schwarz HM8118
  
  
- 18) Oscilloscope Tektronix dpo 3014
  
  
- 19) Oscilloscope Tektronix tds 3014

20) Oscilloscope Tektronix tds 3032

21) Multifunction Calibrator Fluke 5720A

22) Transconductance Amplifier Fluke 52120A

and a lot of electronics from National Instrument...